

STELCOR[®]

DRILLED-IN DISPLACEMENT MICROPILES INSTALLED WITH
NO VIBRATION + NO NOISE





GREATER LOADS. LESSER DEPTHS. IN LESS TIME.

The STELCOR pile takes advantage of the strengths of steel and grout, uses relatively small installation equipment, produces no spoils and consistently produces better results than were projected in design. The load bearing soil is displaced and not removed. The end result is greater loads at lesser depths. The STELCOR pile is embedded into the improved soil with a unique corrugated weave of grout which greatly enhances the soil bond and load transfer capacity.

From structural, geotechnical, mechanical, and installation standpoints, STELCOR just makes sense, and the load test results prove it.

HOW IT WORKS

STELCOR Drilled-In Displacement Micropiles are installed using hydraulic powered rotary equipment and are turned into the ground while crowd or downward pressure is exerted on the steel core and a continuous flow of grout is provided to the top of the pile. Reverse fighting welded to the steel core draws the grout into the annulus created by a displacement head located near the tip of the steel core.

The welded reverse fighting ensures a continuous grout column and structural load transfer from the grout column into the high strength steel core.

Grout ports in the steel core also provide consistent grout placement along the length of the pile.

No soil is removed during installation of STELCOR Drilled-In Displacement Micropiles and the steel cores are left in the ground at each location.

The STELCOR displacement lead section includes a drive plate, a lateral displacement plate and a secondary deformation structure.

The driving plate helps advance the pile downward and provides end bearing support which can be used for total axial capacity when required.

The lateral displacement plate creates a positive annulus around the steel core by displacing the soil outward, enhancing soil density surrounding the pile element.

The secondary deformation structure produces a ribbed or corrugation effect along the grouted pile shaft, greatly enhancing soil bond and load transfer.

A continuous grout column is thereby created by means of the STELCOR displacement lead section and reverse fighting. The structural steel core extends the entire length of the pile ensuring unbroken structural integrity.

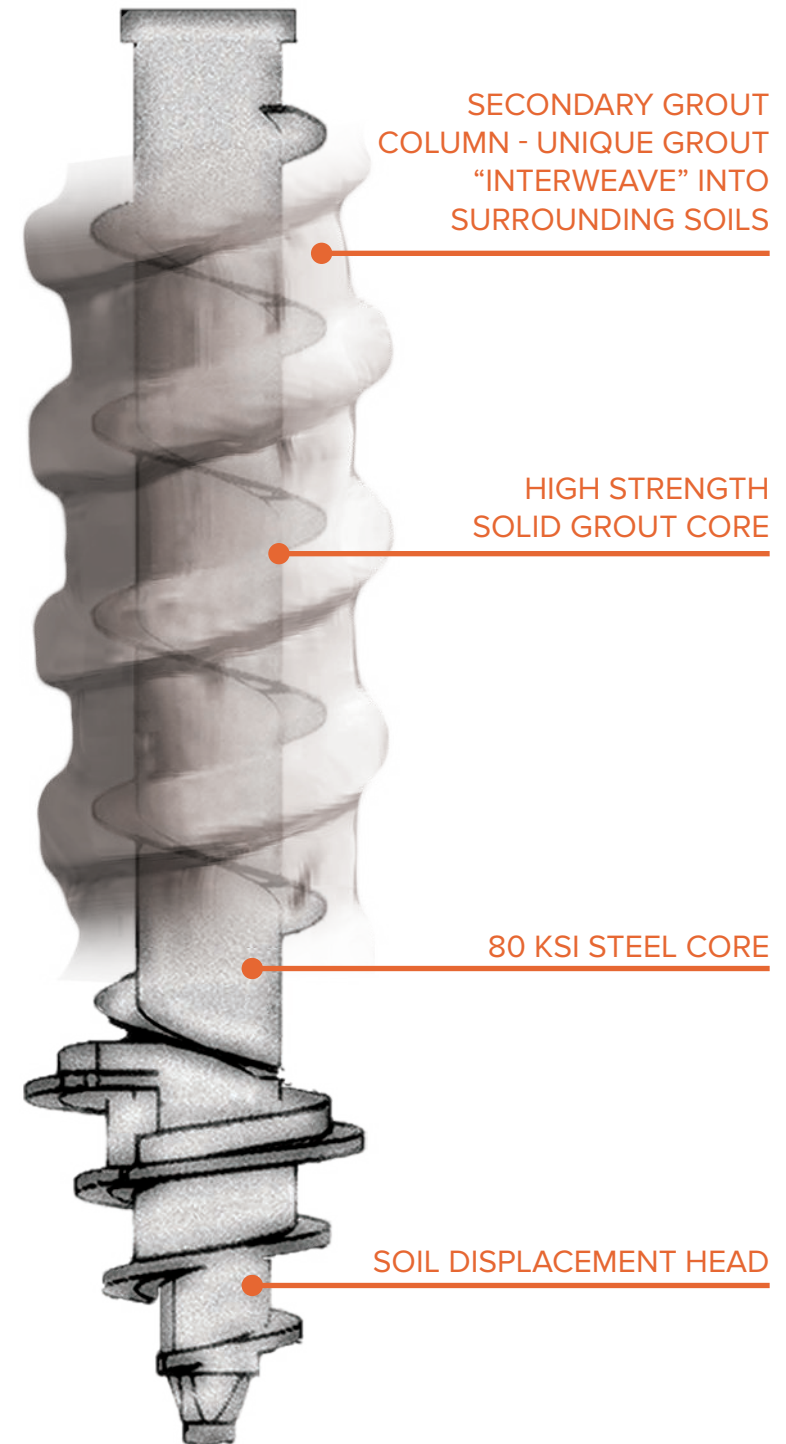

FEATURES+BENEFITS

VIBRATIONLESS INSTALLATION CAUSES NO DISRUPTION TO THE SURROUNDING PROPERTIES

NO SOIL IS REMOVED DURING INSTALLATION

NO SPOILS OR CROSS CONTAMINATION

NO REMOVAL COSTS OR ENVIRONMENTAL CONCERNS

CAN BE INSTALLED IN HIGH WATER TABLES

POSITIVE GROUT PLACEMENT

HIGHER CAPACITIES FOR COMPARABLE CROSS-SECTIONAL AREA OF STEEL AND GROUT

MINIMAL MOBILIZATION AND DEMOBILIZATION COSTS

LOWER COST PER KIP OF SUPPORT COMPARED TO OTHER PILE TYPES

EXCEPTIONAL LATERAL CAPACITY

PREDICTABLE GROUT VOLUMES AND PLACEMENT



INSTALLATION

INSTALLATION SEQUENCE AND GROUT TAKE ESTIMATION FOR STELCOR

PART 1 – GENERAL DESCRIPTION

STELCOR piles are installed using hydraulic powered rotary equipment and are turned into the ground while crowd or downward pressure is exerted on the steel core and a continuous flow of grout is provided to the top of the pile. A reverse flighting welded to the steel core/hollow bar draws the grout into the annulus created by a displacement head located near the tip of the steel core.

PART 2 – INSTALLATION SEQUENCE

1. A STELCOR lead section is located over the pile point location.
2. The hydraulic drive head is attached to the pile end before or after step one.
3. The drive head must be of sufficient torque to install the pile to the specified depth or at least the maximum torque recommended on the steel core/hollow bar.
4. The STELCOR lead section is advanced to approximately 30” below ground level and the flow of grout is then commenced.
5. Grout shall be flowable type 1 or 2 portland cement mixed 1- 94lb. bag to 5 gal potable water. Where the pile length exceeds 23ft. a colloidal mixer shall be used.
6. Grout shall flow continuously to fill the annulus created by the STELCOR displacement head, and shall keep the grout level between ground level and -24” throughout installation.
7. Where extensions are used, stop the drive head and remove from pile end by removing drive pins as necessary.
8. Install a STELCOR extension section and connect with bolts provided.
9. Reattach the drive head and continue turning the pile in to the minimum depth or torque requirement indicated in the pile design. Maintain a continuous level of grout throughout the pile installation.
10. If the final installation termination is above the cut-off height, cut the steel core using an appropriate method such as a portable band saw or torch.
11. Upon completion of pile driving, ensure that the grout level along the annulus is maintained to within 18” of finish pile top on the inside and outside of pile.
12. Install the pile cap provided (or rebar) while the grout is still fluid if grout level is brought to top of pile. Bolt on shear heads may be installed at a later date if grout does not interfere.
13. Document installation torque every 5’ during installation. Pile capacity is not determined by installation torque and data is used as reference only.
14. Document final installation torque at termination. Pile capacity is not determined by installation torque and data is used as reference only.

PART 3 – GROUT TAKE APPROXIMATIONS

This calculation was made using recommended grout mix of 1- 94lb. bag of type 1 or 2 Portland cement to 5 gallons of potable water.

- STELCOR 800 - 5 lineal ft. per bag
- STELCOR 1000 - 3.5 lineal ft. per bag
- STELCOR 1200 - 3 lineal ft. per bag
- STELCOR 1400 - 2.6 lineal ft. per bag
- STELCOR 1600 - 1.7 lineal ft. per bag

APPLICATIONS

STELCOR is the perfect solution when the objective is to achieve high axial load capacities in extremely poor soils at comparatively shallow depths. STELCOR repeatedly delivers higher than expected load test results in compression, tension, and lateral applications.

The lower cost per kip of support compared to other pile types makes STELCOR an extremely competitive alternate on projects requiring a deep foundation solution.

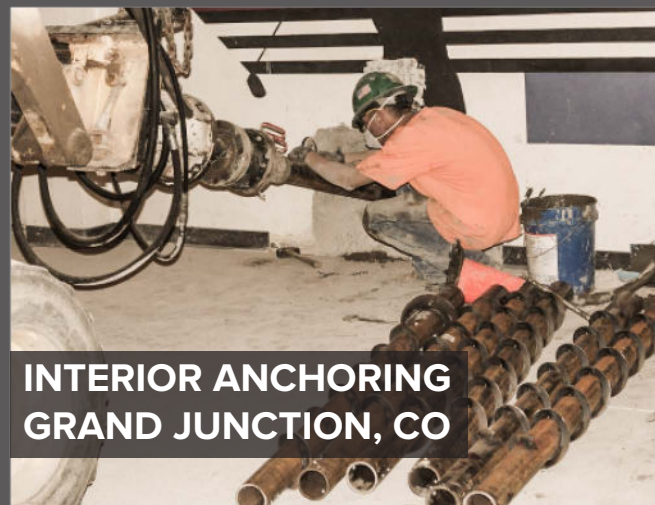

MULTI-STORY NEW CONSTRUCTION

SANITARY PIPELINE SUPPORT

STORAGE SILO FOUNDATIONS

WORK CAMP FOUNDATIONS

TOWERS – QUAD BASE

UTILITY ANCHORING

COMMERCIAL BUILDING REMEDIATION

SUBSTATIONS

TIE-DOWNS/MOORINGS

SOUND WALLS

ROADWAY SIGNAGE TRAFFIC SIGNALS

BILLBOARD/SIGNAGE GENERATOR BASES

BRIDGE SUPPORT

BULKHEADS

SHORING PIPELINE

MACHINE BASES

STORAGE TANKS AND SILOS

TIE-BACKS/ANCHORS/RETAINING WALLS





OUR MISSION

To provide our clients and associates with proprietary technology, products, equipment, and support, ensuring excellence in the design and performance of deep foundation and earth anchoring projects.